

# LOS RIOS COMMUNITY COLLEGE DISTRICT

**PURCHASE ORDER NO 0001103073**

PURCHASING: (916) 568-3071 • FAX: (916) 568-3145  
 ACCOUNTING OPS: (916) 568-3065 • FAX: (916) 286-3636

<b>Date</b> 12/14/2018	<b>Revision</b> 2 - 12/17/2018	<b>Page</b> 1
<b>Payment Terms</b> NET 30	<b>Freight Terms</b> Shipping Point	<b>Ship Via</b> Best Metho
<b>Reference:</b> 1016107 SAATIA HANEYB		<b>Location / Dept</b> 04ASPH130 SME

PLEASE SEE REVERSE SIDE FOR TERMS AND CONDITIONS.

**Supplier:** 0000006424  
 AMAZON.COM  
 BILLING DEPARTMENT  
 P O BOX 80463  
 SEATTLE WA 98108

**Ship To:** FOLSOM LAKE COLLEGE  
 RECEIVING  
 10 COLLEGE PARKWAY  
 FOLSOM CA 95630-6798  
 United States

**email:**

**Bill To:** 1919 Spanos Court  
 Sacramento CA 95825-3981  
 United States

Tax Exempt? N

Line-Sch	Item/Description	Quantity	UOM	PO Price	Extended Amt	Due Date
1- 1	CLEAN ROOM HOOD  BY SENTRY AIR SYSTEMS, INC. 18" WIDE PORTABLE CLEAN ROOM	1.00	EA	1,742.00	1,742.00	12/12/2018
2- 1	SHIPPING & HANDLING	1.00	EA	21.99	21.99	12/12/2018

PO number: 0001103073

Order Number: 113-9263081-7735439

18" Wide Portable Clean Room will be shipped to FOLSOM LAKE COLLEGE by Sentry Air Systems, Inc..  
 Estimated delivery: Jan. 2, 2019 - Jan. 10, 2019

<b>Sub Total Amount</b>	1,763.99
<b>Sales Tax Amount</b>	136.71
<b>Total PO Amount</b>	1,900.70

BU	Acct	Fd	Org	Prog	Sub	Proj	Amount	BYear
GENFD	6490	12	FL.VI.SWPA	61900	00000	481Y	1,900.70	2019

0001016107CHAVEZA12-DEC-2018

Verification of this purchase order can be made using the Los Rios Community College District web site listed below.  
 If you have any questions, please contact the Purchasing Office at (916)568-3071.

<http://www.losrios.edu/purchasing/povalidation>

All shipments, invoices, and correspondence must be identified with our Purchase Order Number. Overshipments will not be accepted unless authorized by Buyer prior to shipment.

**Authorized Signature**

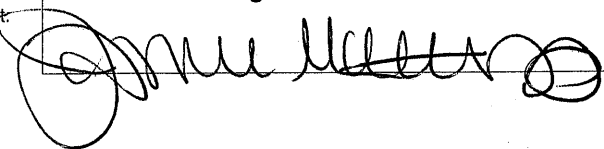

Notice to vendor: You are responsible for delivering goods and delivery documents to the Receiving Department at the site. Failure to do so will delay payment processing. Vendor is responsible for obtaining verification of delivery by authorized Receiving Room personnel. Receipt of goods by other parties and failure to obtain authorized signatures may also delay payment. NOTE: PAYMENT TERMS NET 30  
 MATERIAL SAFETY DATA SHEETS (MSDS) must be provided with the delivery of product as required by law.

## LOS RIOS COMMUNITY COLLEGE DISTRICT

American River College • Cosumnes River College • Folsom Lake College • Sacramento City College

### PURCHASE ORDER TERMS AND CONDITIONS

1. **APPLICABLE LAW:** The contract resulting from this order shall be governed by the laws of the State of California
2. **COMPLETION OF ORDERS:** LRCCD reserves the right to withhold payment until order is completed.
3. **DISCOUNTS:** Please show cash payment discount offered on your invoice in connection with any discount offered, time will be computed from date of delivery of the supplies or equipment, or from date correct invoices are received in the office specified by LRCCD if the latter date is later than the date of delivery. Payment is deemed to be made for the purpose of earning discount, on the date payment is mailed or on behalf of LRCCD.
4. **INVOICES:** Invoices shall be prepared and submitted in duplicate unless otherwise specified. Invoices shall contain Purchase order number, date, description of items, sizes and quantities, unit prices, extended totals, place and date of delivery. Invoices or vouchers not on printed bill heads shall be signed by the CONTRACTOR or person furnishing the supplies or services. Every invoice shall be properly itemized. If LRCCD has not received billing for product or services within a one year period LRCCD will not be held responsible for satisfying the debt.
5. **CHANGES:** No change or modification in terms, quantities, or specifications may be made without express authorization in writing from the LRCCD Purchasing Office and signed by the parties hereto, and no oral understanding or agreement not incorporated herein shall be binding on any of the parties hereto. If unit cost of any item exceeds the amount shown by 10% or \$250.00 whichever is less do not ship. Contact LRCCD Purchasing at the phone number provided.
6. **BILL OF LADING:** If Bill of Lading is applicable to this order, send originals to "Ship to" address and duplicate Bill of Lading with invoices to "Bill to" address. All correspondence, invoices, bills of lading, shipping memos, packages, etc., must show purchase order number. If factory shipment, advise factory to comply.
7. **TRANSPORTATION CHARGES:** Invoices for prepaid transportation charges must be supported by original receipted expense bills.
8. **FOB POINT AND FREIGHT CHARGES:** Unless otherwise specified on this order, all items shall be delivered FOB Destination. No charge for delivery, drayage, express, parcel post, packing, cartage, insurance, license fees, permits, or for any other purpose will be paid by LRCCD unless expressly included and itemized in the order. Unless otherwise shown, on "FOB Shipping Point" transactions, CONTRACTOR shall arrange for lowest cost transportation, prepay and add freight to invoice and furnish supporting freight bills if the amount exceeds \$50.00. On "FOB Shipping Point" transactions, should any shipments under this purchase order be received by LRCCD in a damaged condition and any related freight loss and damage claims filed against the carrier or carriers be wholly or partially declined with the inference that damage was the result of the act of the shipper such as inadequate packaging or loading or some inherent defect in the equipment and/or material, CONTRACTOR on request of LRCCD shall at CONTRACTOR's own expense assist LRCCD in establishing carrier liability by supplying evidence that the equipment and/or materials was properly constructed, manufactured, packaged, and secured to withstand normal transportation conditions. Shipments that are California intrastate in nature and where freight is to be borne by LRCCD shall be tendered to carriers with written instructions that rate and charges may not exceed the lowest lawful rates on file with the California Public Utilities Commission.
9. **PATENT INDEMNITY:** The CONTRACTOR shall hold LRCCD, its officers, agents and employees harmless from alleged liability of any nature or kind, including costs and attorney fees and expenses, for infringement or use of any copyrighted or uncopyrighted composition, secret process, patented or unpatented invention, article or appliance furnished or used in connection with the contract or purchase order.
10. **TAXES:** Certain articles sold to LRCCD are exempt from certain Federal excise taxes. LRCCD will reimburse the CONTRACTOR for, or pay directly, all California State and local sales and use taxes applicable to this purchase.
11. **EQUAL OPPORTUNITY EMPLOYER:** The acceptance of this purchase order by a supplier of goods and services is a certification that such supplier complies with all provisions of executive order 11246 and is an equal opportunity employer.
12. **GENERAL SAFETY ORDERS:** All materials, supplies and services sold to LRCCD shall conform to the general safety orders of the State of California. All materials, except as otherwise specified, must be new and of the best quality of their respective kinds.
13. **INDEMNIFICATION:** CONTRACTOR shall indemnify, defend and hold harmless LRCCD, its trustees, officers, agents, employees and volunteers, from any and all claims, demands, suits, causes of action, damages, penalties, breaches of this agreement, infringement of patent rights, costs, expenses, violations of employee occupational health and safety laws, attorney fees, losses or liability, property damage, personal injuries to or death of persons, arising out of, alleged to have arisen out of, or relating in any way to CONTRACTOR's work to be performed under this agreement, except if caused solely by the negligence of LRCCD.
14. **TERMINATION:** LRCCD may terminate this agreement and be relieved of the payment of any consideration to CONTRACTOR should CONTRACTOR fail to perform the covenants herein contained at the time and in the manner herein provided. In the event of such termination LRCCD may proceed with the work in any manner deemed proper by LRCCD. The cost to LRCCD shall be deducted from any sum due the CONTRACTOR under this agreement and the balance if any, shall be paid the CONTRACTOR upon demand.
15. **ASSIGNMENT:** Without the written consent of LRCCD, this agreement is not assignable by CONTRACTOR either in whole or in part.
16. **PUBLIC WORKS PROJECTS:** CONTRACTOR must comply with Public Contract Code.
17. **CA LABOR CODE:** Pursuant to Section 1700, and following, the CONTRACTOR shall pay not less than the prevailing rate of per diem wages as determined by the Director of the California Department of Industrial Relations. Copies of such prevailing rate of per diem wages are on file at the Business Office of the Los Rios Community College District, 1919 Spanos Court, Sacramento, CA 95825. Those copies shall be made available to any interested party upon request. The CONTRACTOR shall forfeit, as penalty to the LRCCD, Fifty Dollars (\$50.00) for each calendar day or portion thereof, for each workman paid less than the stipulated prevailing rates for any work done under the contract by him/her or by any subcontractor under him, in violation of the provisions of such Labor Code.
18. **NOTICE:** Your employees may be exposed to hazardous substances during the course of their work while on LRCCD property. For additional information on the hazardous substances that your employees may be exposed to contact the LRCCD General Services Department at (916) 568-3048.
19. **INSURANCE:** CONTRACTOR shall, at all times, maintain in full force and effect the following insurance: Workers' Compensation, Commercial General Liability, Auto Liability, and Professional Liability if licensed professional. Policy limits for each shall be at least \$1,000,000 AND \$3,000,000 AGGREGATE for bodily injury, personal injury and property damage. Any combination of General Liability and Excess Coverage can be combined to meet the Aggregate. LRCCD shall be named as an additional insured on CONTRACTOR's policies. The CONTRACTOR shall provide a certificate of insurance and required endorsements to comply with this section at least 15 days prior to commencement of work under this contract. The certificate shall state that LRCCD will be given 30 days notice of any material change or cancellation in coverage.
20. **DISQUALIFIED EMPLOYEES:** CONTRACTOR shall ensure that persons who perform services on LRCCD property have not been convicted of any felony, or any controlled substance offense or any sex offense as those terms are defined by Education Code section 87008-87010. If LRCCD determines that any person employed by CONTRACTOR to work on LRCCD property is incompetent, unfaithful, intemperate, disorderly, abusive or is otherwise unsatisfactory, CONTRACTOR shall cause that employee to be removed from working on LRCCD property immediately, and that person shall not be employed again on LRCCD property.
21. **WORK AUTHORIZATION:** Prior to LRCCD's acceptance of this Agreement, CONTRACTORS who are not U.S. citizens must provide verification of (a) work authorization status from the appropriate U.S. Department of State; (b) a copy of their U.S. visa; (c) the number of days present in the U.S.; and (d) tax treaty status. LRCCD shall not make any payments to CONTRACTOR unless CONTRACTOR holds the appropriate U.S. visa. CONTRACTOR is responsible for ensuring they are in possession of the appropriate visa.
22. **WARRANTY:** CONTRACTOR expressly warrants that all materials, goods, equipment, services, and/or labor shall conform to the requirements set forth or incorporated into this order and any applicable industry standards or requirements, shall be merchantable and free from defects in workmanship, materials and/or design (including latent defects), and shall perform as specified. CONTRACTOR further warrants that all materials, goods, equipment, services, and/or labor will be fit and sufficient for the particular purposes intended by LRCCD. Unless agreed upon otherwise between LRCCD and CONTRACTOR, the warranty period shall be the longer of: (a) any express warranty included in this service agreement; (b) one year after the materials, goods, equipment, services, and/or labor are accepted by LRCCD; or (c) any warranty period provided under any applicable California law.

# Requisition

**Supplier:** AMAZON.COM  
 BILLING DEPARTMENT  
 P O BOX 80463  
 SEATTLE WA 98108  
 United States

000006424

<b>Business Unit:</b> GENFD OPEN	
Req ID: 0001016107	Date: 11/28/2018
Page: 1	
Requisition Name: 2019 AMAZON.COM	
Requester: Amira Saati	Bldg#: SME
Requester Signature	
Buyer: Suzanne Rouiller	
Approved:	
Entered By: SAATIA 28-NOV-2018	

**email:**

**Ship To:** RECEIVING  
 10 COLLEGE PARKWAY  
 FOLSOM CA 95630-6798

Line-Schd	Description	Quantity	UOM	Price	Extended Amt	Due Date
1-1	CLEAN ROOM HOOD	1	EA	1,742.00	1,742.00	12/12/2018
	BY SENTRY AIR SYSTEMS, INC. 18" WIDE PORTABLE CLEAN ROOM					

ASSET DEPT: SME      LOCATION: 04ASPH130      CATEGORY: EQUIP      1      PROFILE: EQP:OTHER

2-1	SHIPPING & HANDLING	1	EA	21.99	21.99	12/12/2018
-----	---------------------	---	----	-------	-------	------------

ASSET DEPT: SME      LOCATION: 04ASPH130      CATEGORY: SHP      1      PROFILE: EQP:OTHER

1,763.99 Sub-total  
 136.71 Est. tax

Total Requisition Amount: 1,900.70

Web Pricing

BU	Acct	Fd	Org	Prog	Sub	Proi	Amount
GENFD	6490	12	FL.VI.SWPA	61900	00000	481Y	1,763.99

**Purchases Charged to Catagorical Programs, Grants or Special Project.**

This purchase is in compliance with the requirement of Strong Workforce

For grants/special projects 481Y

Eligible Equipment

Name: [Signature]

Approval Signature <u>[Signature]</u>	Approval Signature <u>[Signature]</u>	Approval Signature
--	--	--------------------



Estimated delivery: Dec. 11, 2018 - Dec. 19, 2018



**18" Wide Portable Clean Room**

**\$1,742.00**

Usually ships within 6 to 10 days.

**Quantity:** 1 Change

Sold by: Sentry Air Systems, Inc.

Gift options not available.

Choose a delivery option:

**Tuesday, Dec. 11 - Wednesday, Dec. 19**

\$21.99 - Standard Shipping

**Order Summary**

Items:	\$1,742.00
Shipping & handling:	\$21.99
Total before tax:	\$1,763.99
Estimated tax to be collected:*	\$0.00

**Order total: \$1,763.99**

## 18" Wide Portable Clean Room

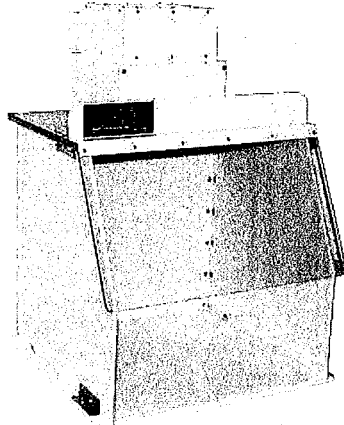

**\$2,299.99**

Free Shipping

Get it by **Thu, Dec 13** - **Mon, Dec 17** from Opelika, Alabama

- New condition
- 30 day returns - Free returns

*"Material Sides: 0.250" White Acrylic, Front: 0.250" Clear Polycarbonate, Base: 0.500" White High Density Polyethylene, Top: 0.500" Clear Polycarbonate."*

[Read full description](#)

[See details](#)

For comparison only

## 18" Wide Portable Clean Room

### Specifications for this item

Part Number	SS-218-PCR
Number of Items	1
Brand Name	Sentry Air Systems, Inc.
Item Weight	35.0 pounds
Material	Sides: 0.250" White Acrylic, Front: 0.250" Clear Polycarbonate, Base: 0.500" White High Density Polyethylene, Top: 0.500" Clear Polycarbonate



Quote for Folsom Lake College

Item:

Clean Room Mini - Portable Positive Pressure  
18" Wide Portable Clean Room  
Model # SS-218-PCR

Item	Description	Quantity	Rate
SS-218-PCR	18" Wide Portable Clean Room: Clean Room Mini - Portable Positive Pressure	1	1,925.00
	Shipping	1	\$26
	Tax	1	\$156

Total Cost: \$2,107

Shipping to:  
Folsom Lake College  
10 College Parkway  
Folsom CA 95630

*For comparison only*

# Positive - Pressure Clean Room Hood

## Portable Clean Room Hood- 18" Wide



### Model # SS-218-PCR

### ISO CLASS 5

### Product Specifications

#### HOOD DIMENSIONS

Interior Dimensions: 18" D x 18" W x 18" H  
Outer Dimensions: 18.5" D x 20" W x 19" H  
Access Area: 8" x 18"

#### HOOD MATERIAL

Sides: 0.250" White Acrylic  
Base: 0.500" White High Density Polyethylene  
Top: 0.500" Clear Polycarbonate  
Front: 0.250" Clear Polycarbonate

#### BLOWER DIMENSIONS

10.5" L x 8" W x 8.5" H

#### BLOWER MATERIAL

16 ga. carbon steel with polyurethane epoxy coating on all surfaces

#### WEIGHT

Approx. 35 lbs.

#### CLASSIFICATION

ISO Class 5

#### AIR VOLUME

Up to 65 CFM FPM Average face velocity  
W/O Curtains.

#### ELECTRICAL

115/1/60, Approx. 0.3 Amps  
220/1/50, Approx. 0.2 Amps  
8' grounded power cord with NEMA 5-15P Plug

#### SOUND LEVEL

Approx. 55 dba @ 3' from hood inlet

#### FILTRATION MEDIA

##### Pre-Filter:

- MERV 8 Pre-filter

##### Main Filter Options:

- HEPA (up to 99.97% efficient on particles 0.3 microns and larger) OR
- ULPA (up to 99.9995% efficient on particles 0.12 microns and larger)

#### WARRANTY

Limited three-year warranty from date of shipment on defects due to materials or workmanship.

PATENT #5,843,197

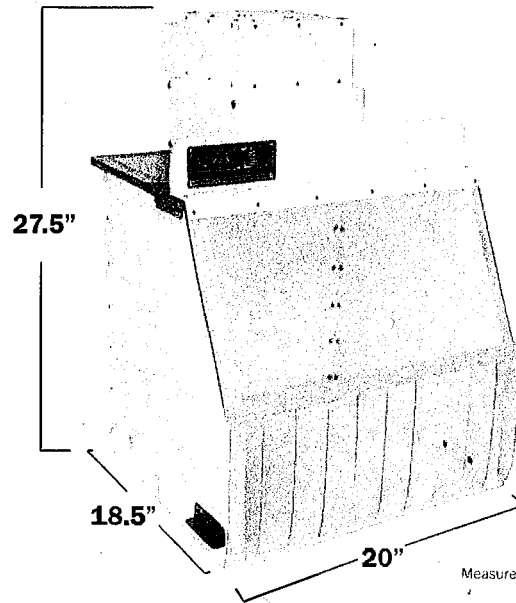

Measurements are approximate.

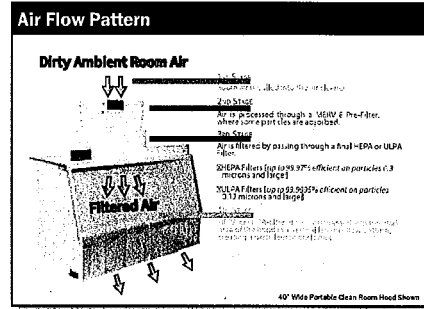

### Product Features

- Clear anti-static vinyl curtains *Included*
- Simple, Quick "No Tool" Filter Change
- Optional Variable Speed Controller (115V only)
- LED Light *Included*
- Reliable, Low Maintenance Operation
- Optional Hour Counter
- Highly Portable and Lightweight
- Long Filter Life
- Optional Removable Spill Tray
- Quiet Operation
- Other Standard Sizes: 12", 24", 30", 40"

For applications that require a compact and clean positive-pressure environment, the **18" Wide Mini Portable Clean Room Hood** may be an excellent choice. This system is rated as an ISO Class 5 clean room cabinet. It utilizes a dual stage filtration process consisting of a pre-filter and a HEPA or ULPA filter. The HEPA filter is up to 99.97% efficient on particles 0.3 microns and larger, while the ULPA filter is up to 99.9995% efficient on particles 0.12 microns and larger.

This portable clean room hood has been utilized in variety of applications including portable field testing, stem cell therapy practices and other medical applications, tissue culturing, data recovery, cleaning processes, manufacturing, and much more.

This unique system features a small footprint, energy-efficiency, and low maintenance operation. The 18" Wide Portable Clean Room Hood can be easily integrated into existing workspaces because of its size and can be transported to various locations without difficulty because of its lightweight and portable nature.

Our line of portable clean rooms are not intended for sterile compounding applications.



713-690-2153  
www.sentryair.com  
sales@sentryair.com

